

VIOLETTA EVO

WOOD COOKERS



The cast iron worked in its highest expression takes on a linear and minimalist shape. Its essential and rational style gives the kitchen a strong and unique personality. Style and elegance enriched with precious handmade majolica tiles with fine decors in relief.

Heatable area

74 m².



DIMENSIONS

TECHNICAL DATA



- 1 - Smoke outlet \varnothing 130mm
- 2 - Smoothed cast iron cooking plate together with cast iron rings
- 3 - Starter
- 4 - Lateral handrail (optional)
- 5 - Cast iron frame
- 6 - Secondary air modulation devices
- 7 - Cast iron firebox door
- 8 - Cast iron firebox (HxWxD - 296x235x353)
- 9 - Loading opening (WxH - 214x273)
- 10 - Ergonomic door handle
- 11 - Enamelled oven (HxWxD - 307x253x333)
- 12 - Primary air modulation devices
- 13 - Food warmer
- 14 - Tools compartment
- 15 - The refined raised base facilities the cleaning operations

Flue outlet options: top - rear

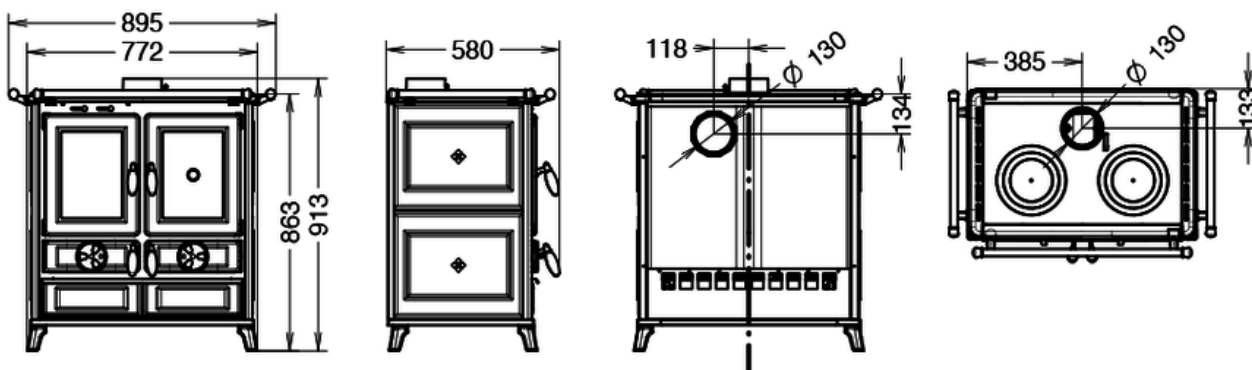

DIMENSIONS (HXWXD)	913X770X578
WEIGHT (KG)	175,00
HEATABLE AREA (M ²)	74
EFFICIENCY UP TO MAX (%)	87,4%
ENERGY CLASS	A+
POWER TO THE HEART (KW)	9,4
RATED POWER (KW)	8,2
POWER TO THE WATER (KW)	-
RADIATION (KW)	8,2
HOURLY PELLET CONSUMPTION (KG/H)	-
WOOD HOURLY CONSUMPTION (KG/H)V	2,2
PELLET HOPPER CAPACITY (KG)	
WARM AIR DUCTING	-
MAXIMUM SINGLE DUCTING OUTLET (M)	-
PATENTED BURNER PELLETPOWER®	

ROOM VENTILATION	-
PRIMARY AIR FROM OUTSIDE	-
CO EMISSIONS (MG/M³; 13% DI O₂)	324
CO EMISSIONS (MG/M³; 10% DI O₂)	
DUST EMISSIONS (MG/M³; 13% DI O₂)	12,0
DUST EMISSIONS (MG/M³; 10% DI O₂)	
SILENCE(DB)	-
REMOTE CONTROL	-
RADIO CONTROL WITH ROOM TEMPERATURE THERMOSTAT	-
WEEKLY PROGRAMMER (3 DAILY LIGHTING)	-
SMART INFO FUNCTION	-
SYSTEM CIRCULATING PUMP	-
EXPANSION TANK	-
OVER PRESSURE VALVE	-
FLUE GASEXHAUST DIAMETER (MM)	130
MIN. FLUE DRAUGHT PRESSURE (PA)	12
ELECTRIC CONSUMPTION (WATT)	-
HIGH TEMPERATURE SAFETY THERMOSTAT	-



CATALOGUES | DEALERS | LEGAL NOTICES

THERMOROSSI S.p.A.

Via Grumolo, 4 | 36011 Arsiero (VI) | Italy | E-mail: export@thermorossi.it

Tel: +39 0445 741310 | Fax: +39 0445 741657 | P.IVA 00168470243 | Iscr. REA99797 Vicenza | Cap. Sociale di 156,000,00 I.v.

